

■ GEBERIT

Benefits from behind the wall:
Geberit concealed cisterns



Bathroom design is changing, and as a result, consumers are no longer bound to the constraints of the traditional exposed cistern. Geberit's concealed cistern herald the advent

of modern bathroom design, utilizing wall hung technology, or floor standing WC, and with it, the design freedom to provide solutions in even the smallest of rooms.



The blue net protects the cistern and gives a basis onto which plaster can directly be applied.



Modern design in front of the wall

Modern technique behind the wall

The Geberit cisterns are known for their outstanding performance: The Geberit filling valve is specially designed for quiet operation. Thus, with a Geberit concealed cistern, you don't just enjoy the benefits of an extremely reliable and efficient system – you get a solution that is pleasing to all your senses. The

Geberit concealed cistern gives you a wide range of applications. Especially the 110.700.00.2, with its thickness of only 90 mm, allows you the installation in a brick wall with less than 120 mm. The maintenance opening for the flushing set and filling valve is specifically designed to allow easy part maintenance (e.g. to adjust the flushing volume).

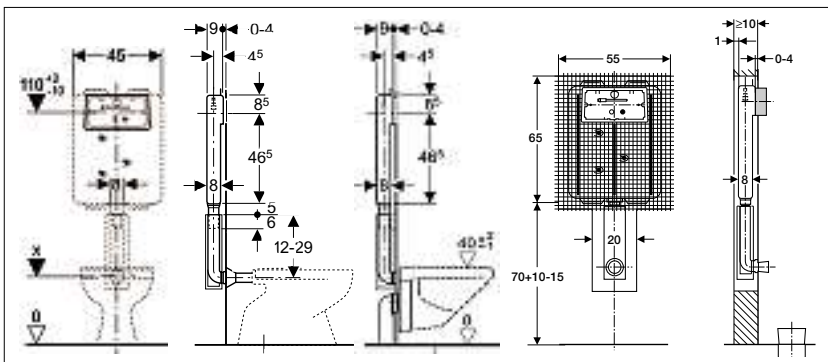

Modern design in front of the wall

Effortless and simple to use, Geberit's dual flush system "Twinline" with 3/6 litres or the "flush/stop" function of the actuator plates "200 F" and "Highline" bring real saving in household water consumption.



Geberit Twinline



Geberit 200 F



Geberit Highline



Geberit pneumatic 115.941



Geberit pneumatic 115.942

Geberit International Sales AG
 CH-8640 Rapperswil
 Switzerland
 Tel.: + 41 55 221 62 00
 Fax: + 41 55 221 67 50
 E-Mail: sales@geberit.com
 www.international.geberit.com